



RANJITH

Design engineer



Engine Trestle Assembly

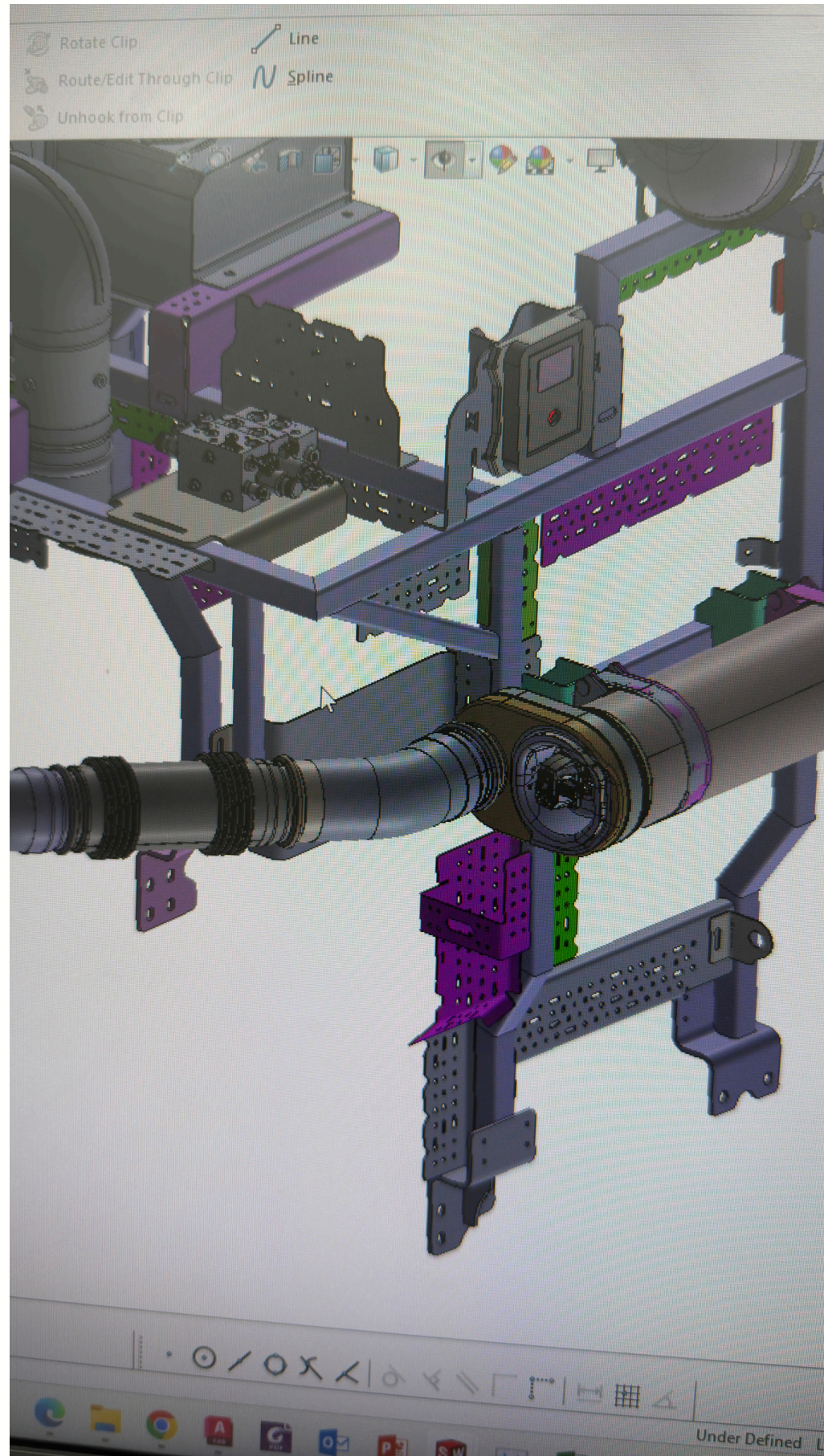

Vehicle Cabin Structure

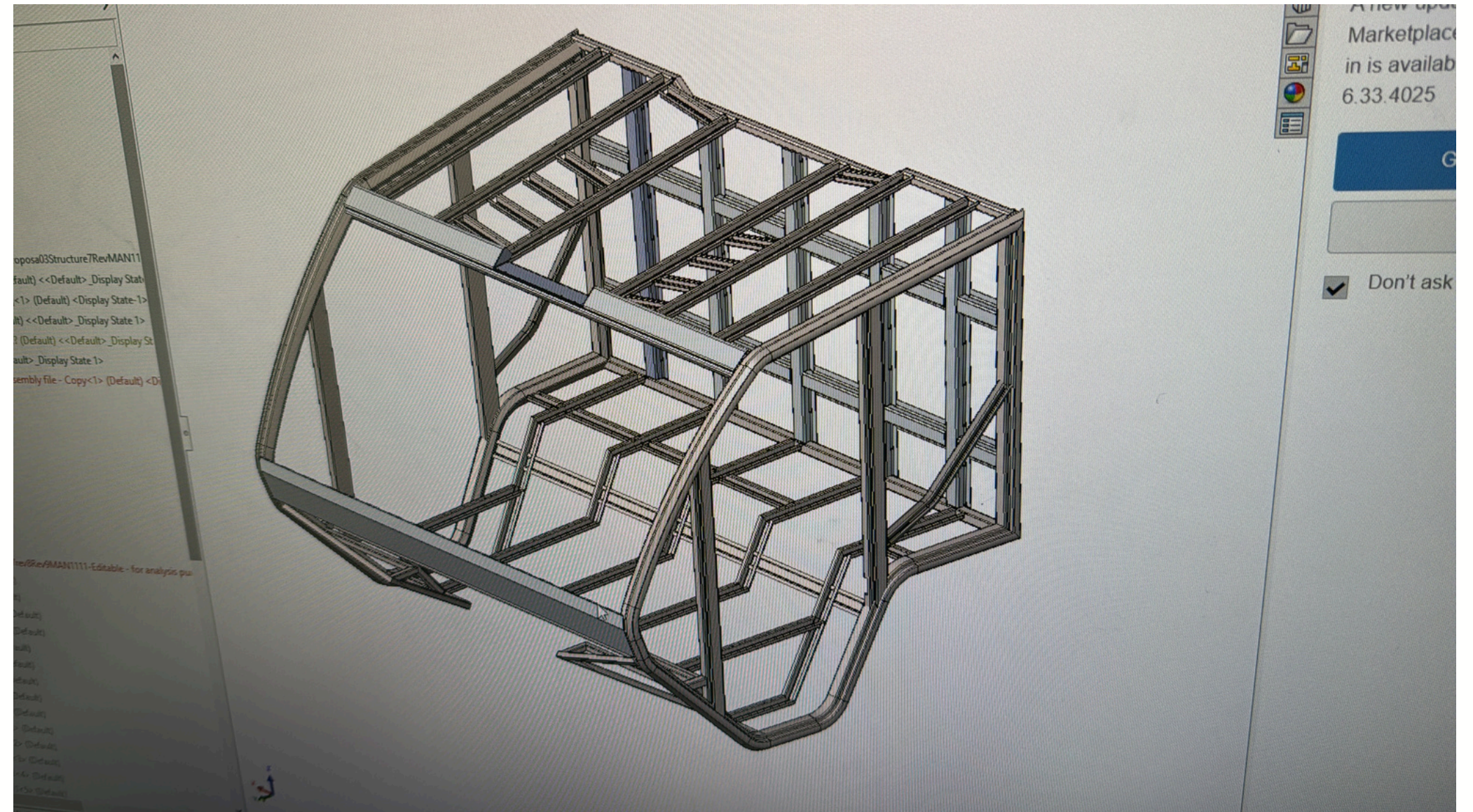

Vehicle Cabin Development-steering position

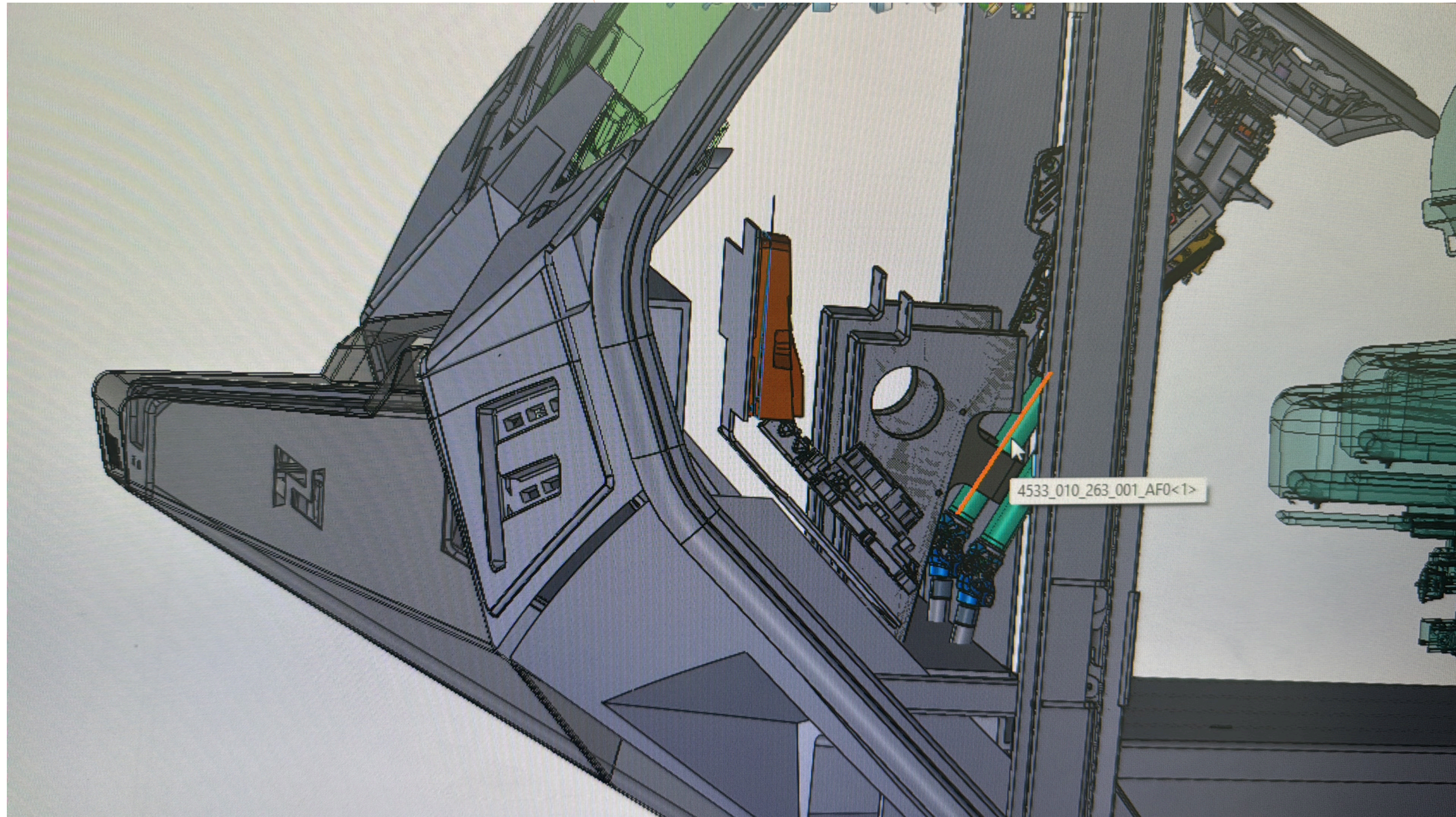

Vehicle Hydrualics system Routings

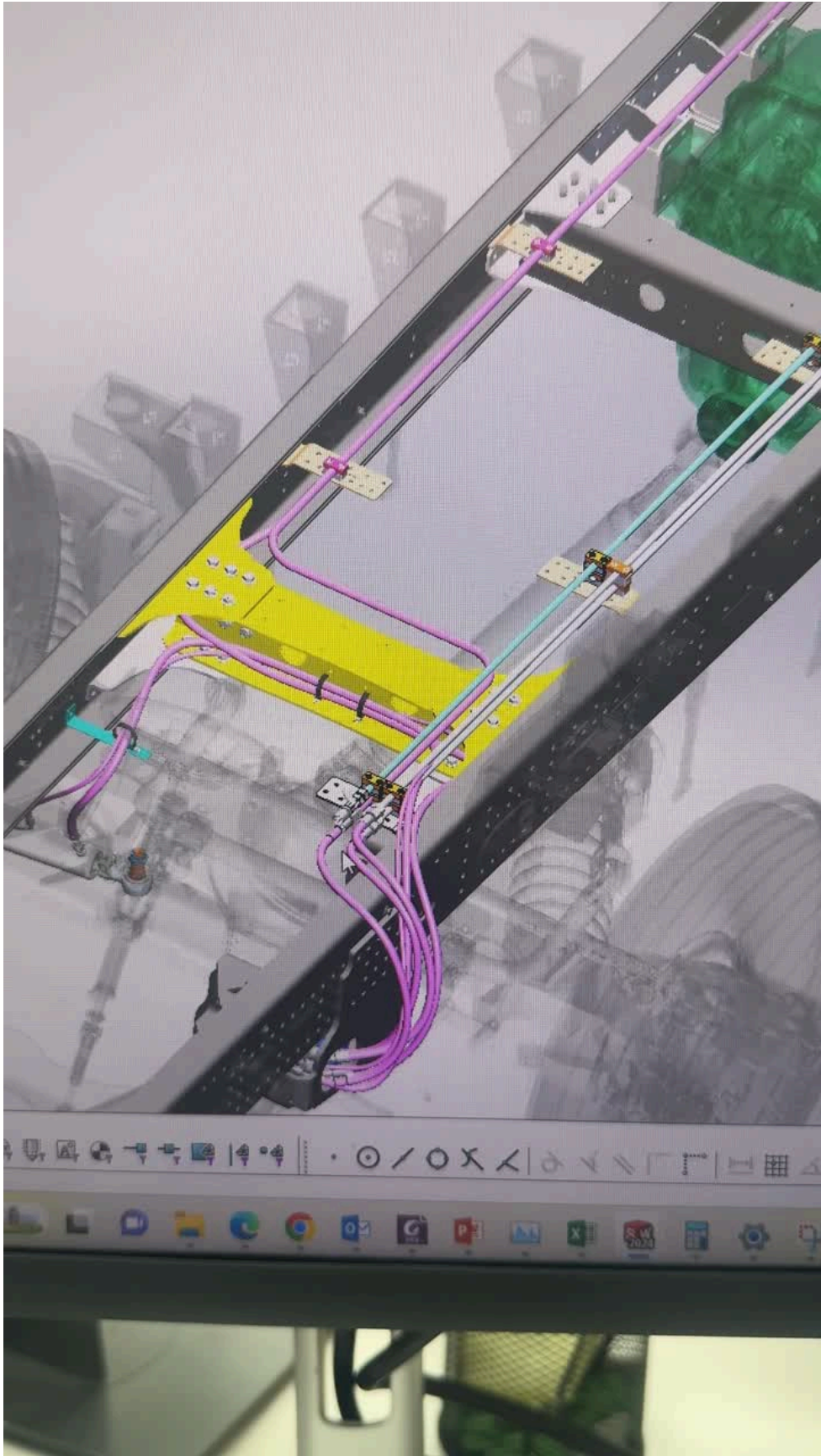

Vehicle rear cabin

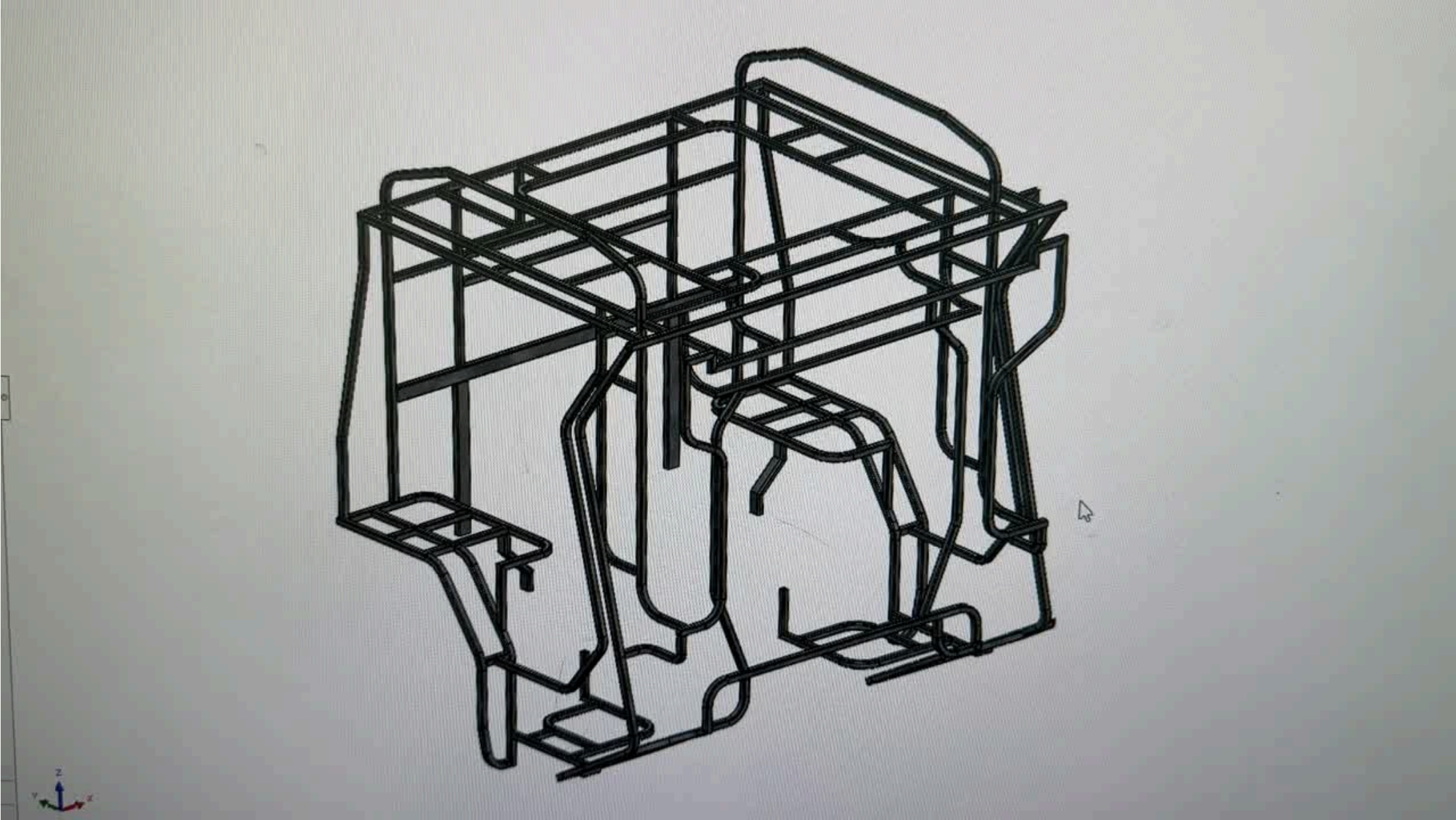

Vehicle HVAC System Routings

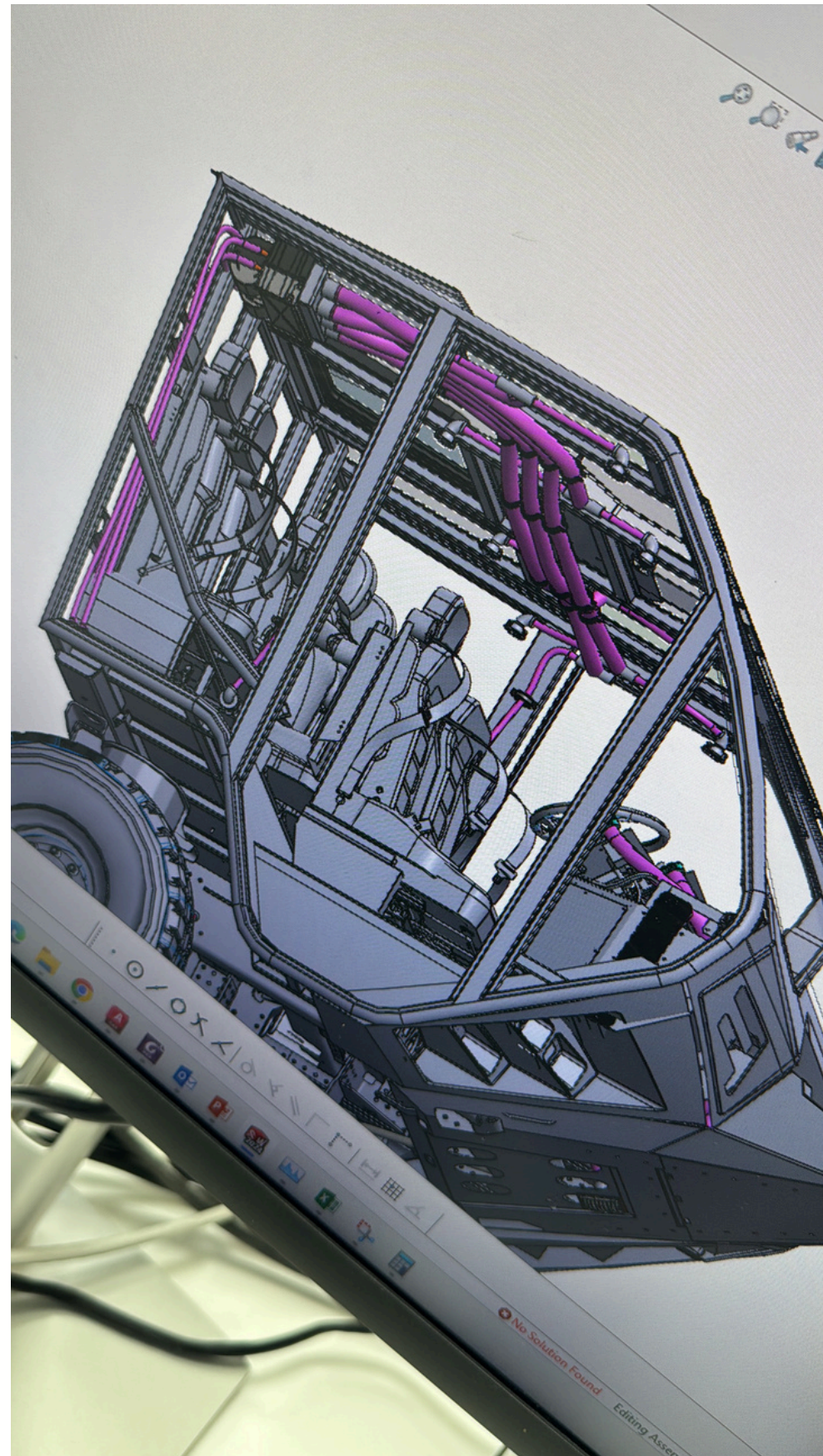

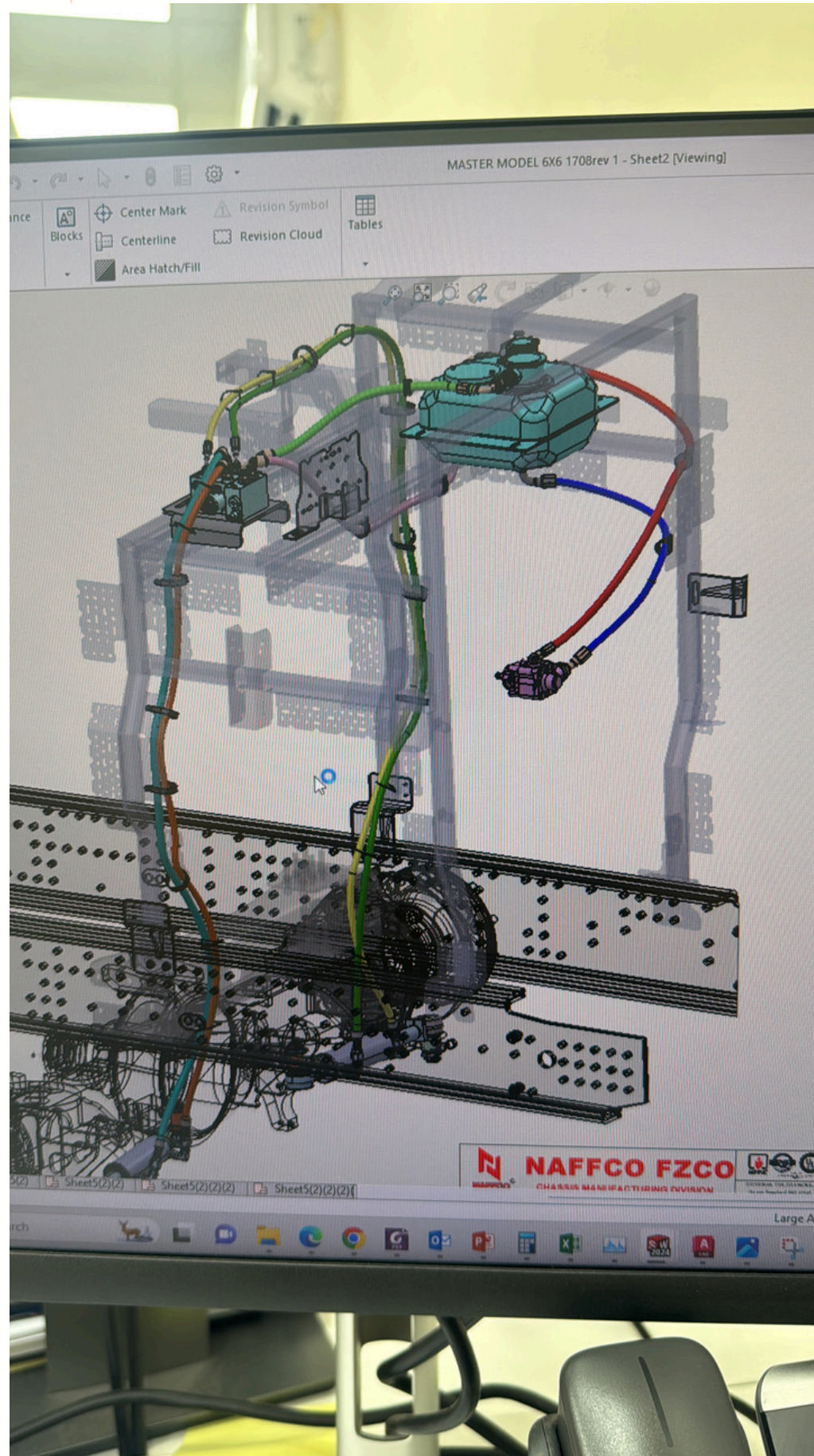
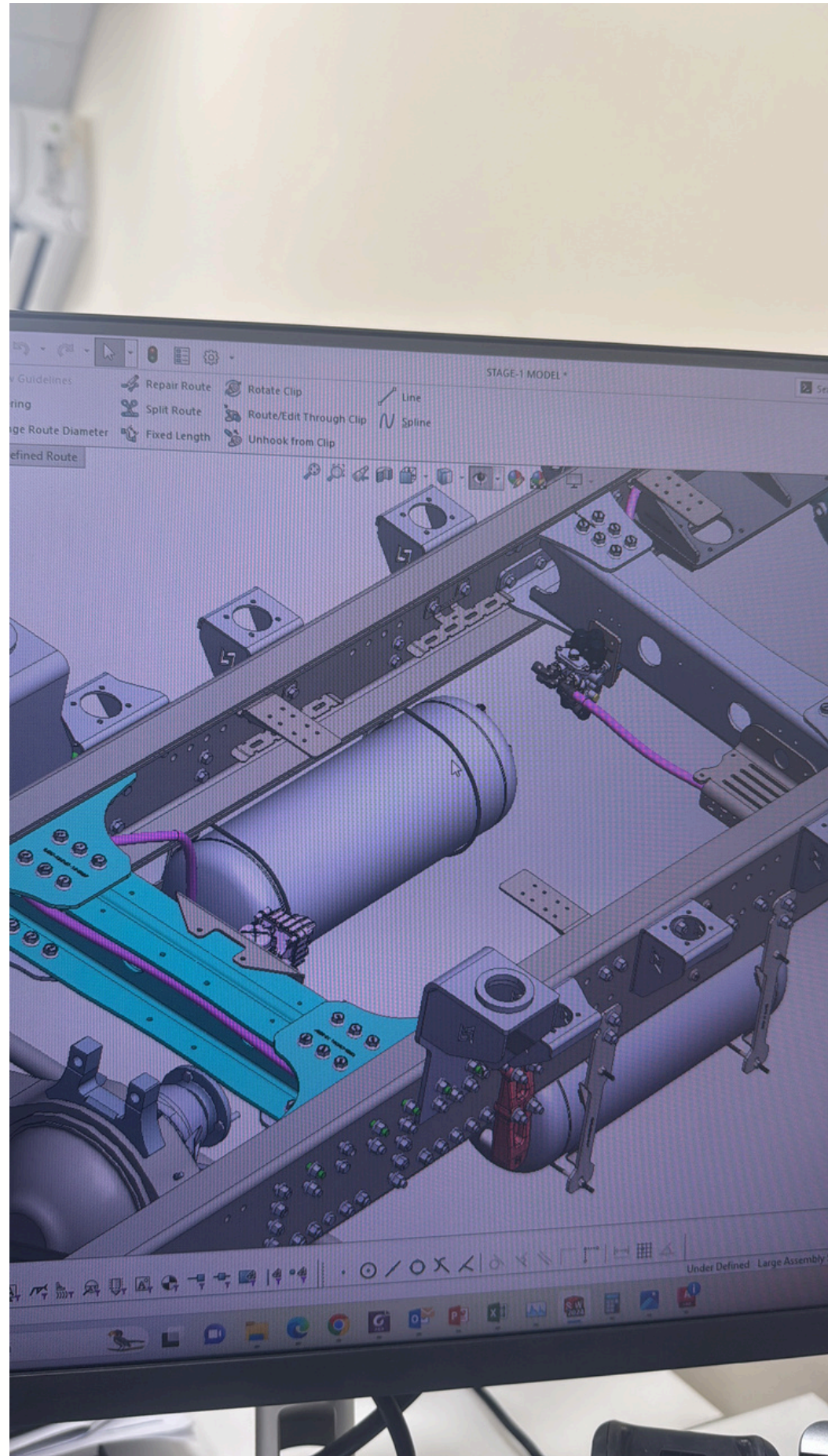

This spanner is create to arrest the down side fitting while apply the torque on top fitting bottom fitting should hold but there is no space in between solving this issuse I created and it's done



BRACKET PROPSAL FOR LOCKING THE ROTATION OF THE FITTING

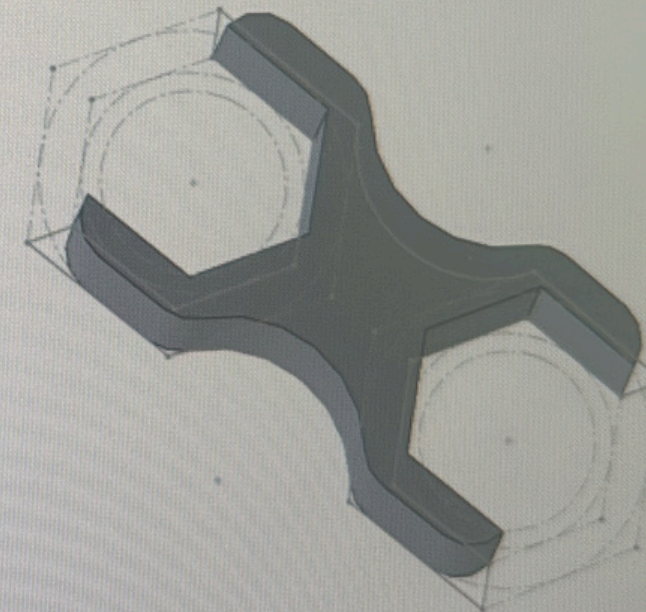
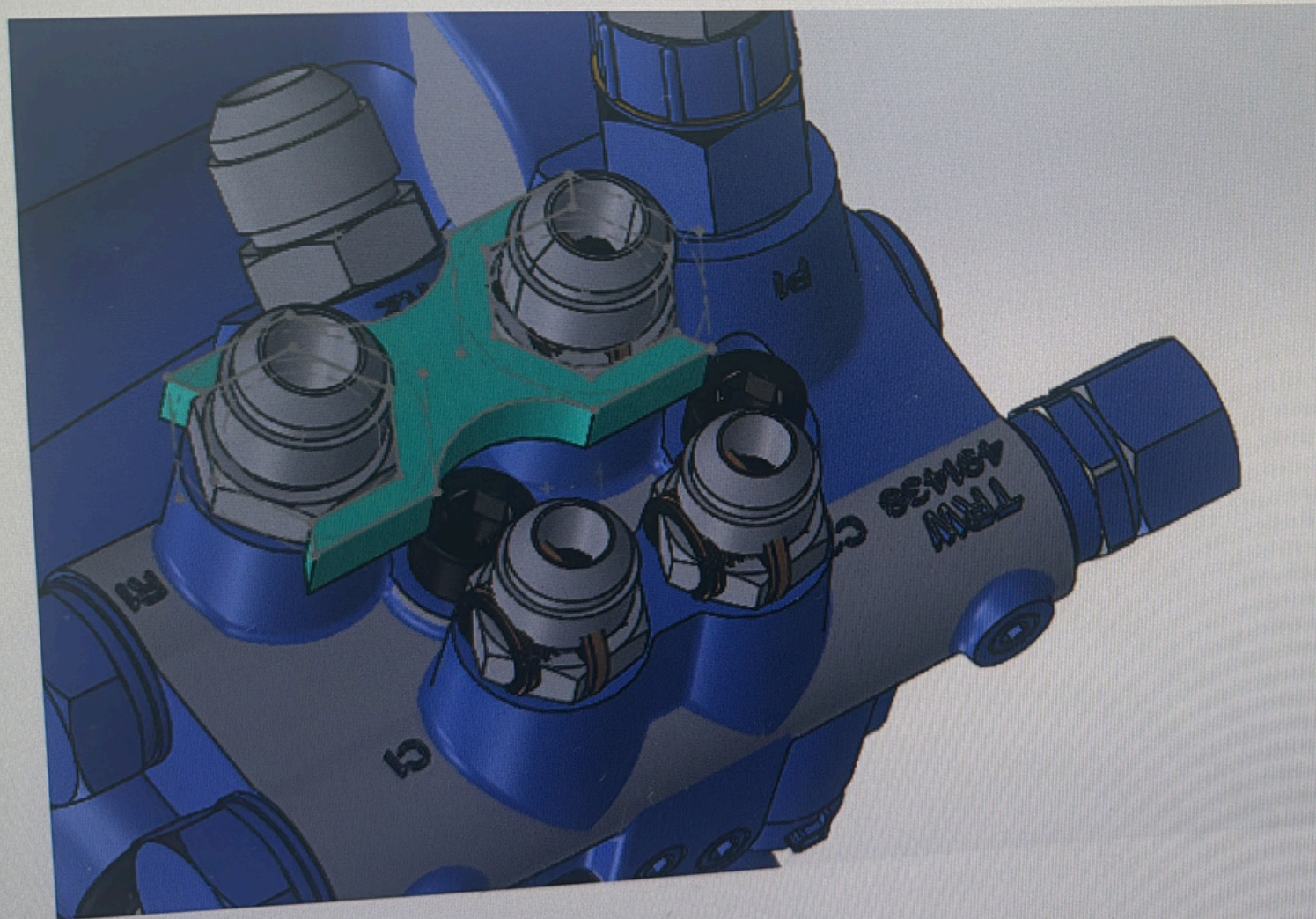



Dashboard Design

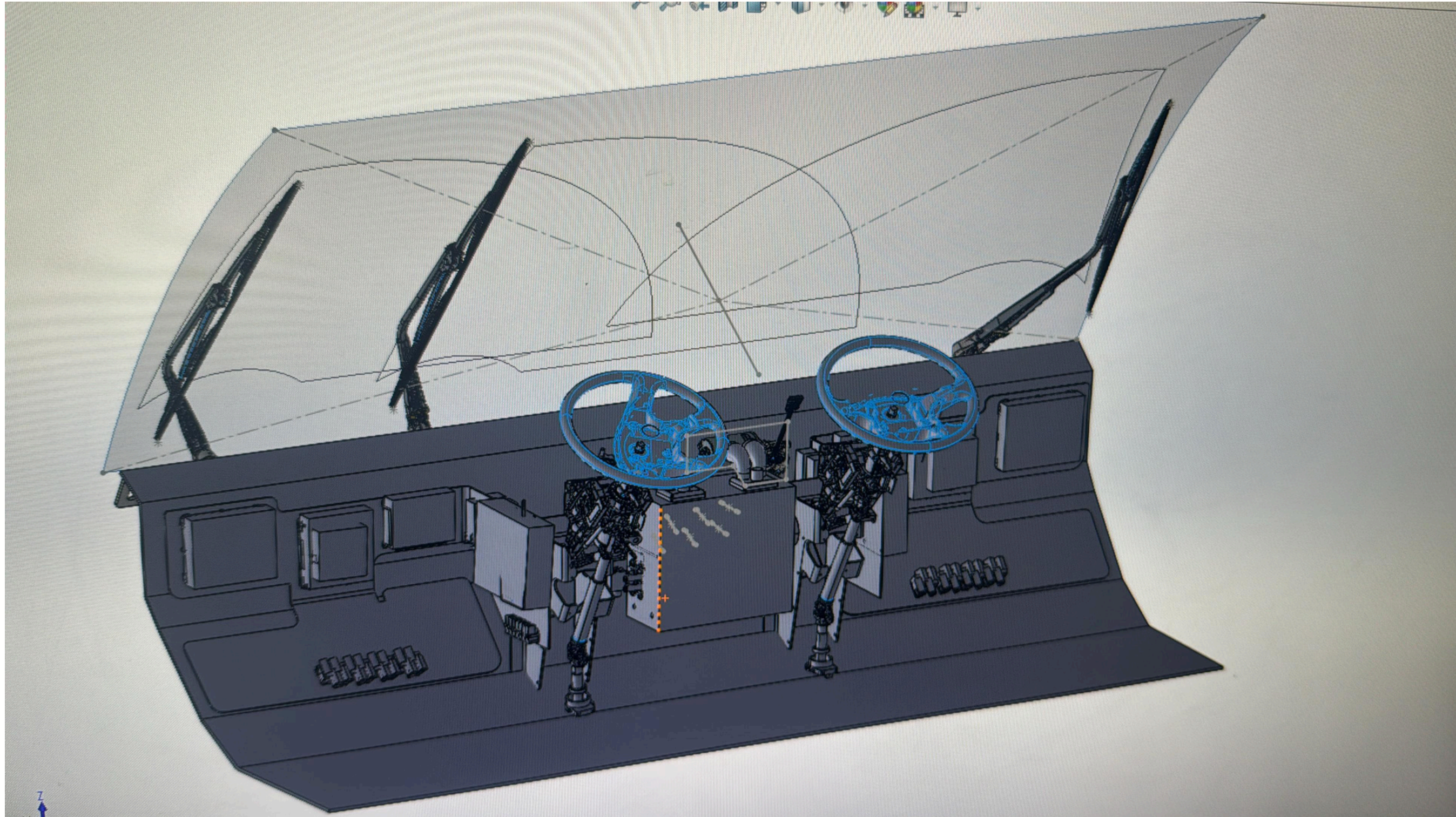

Door Design

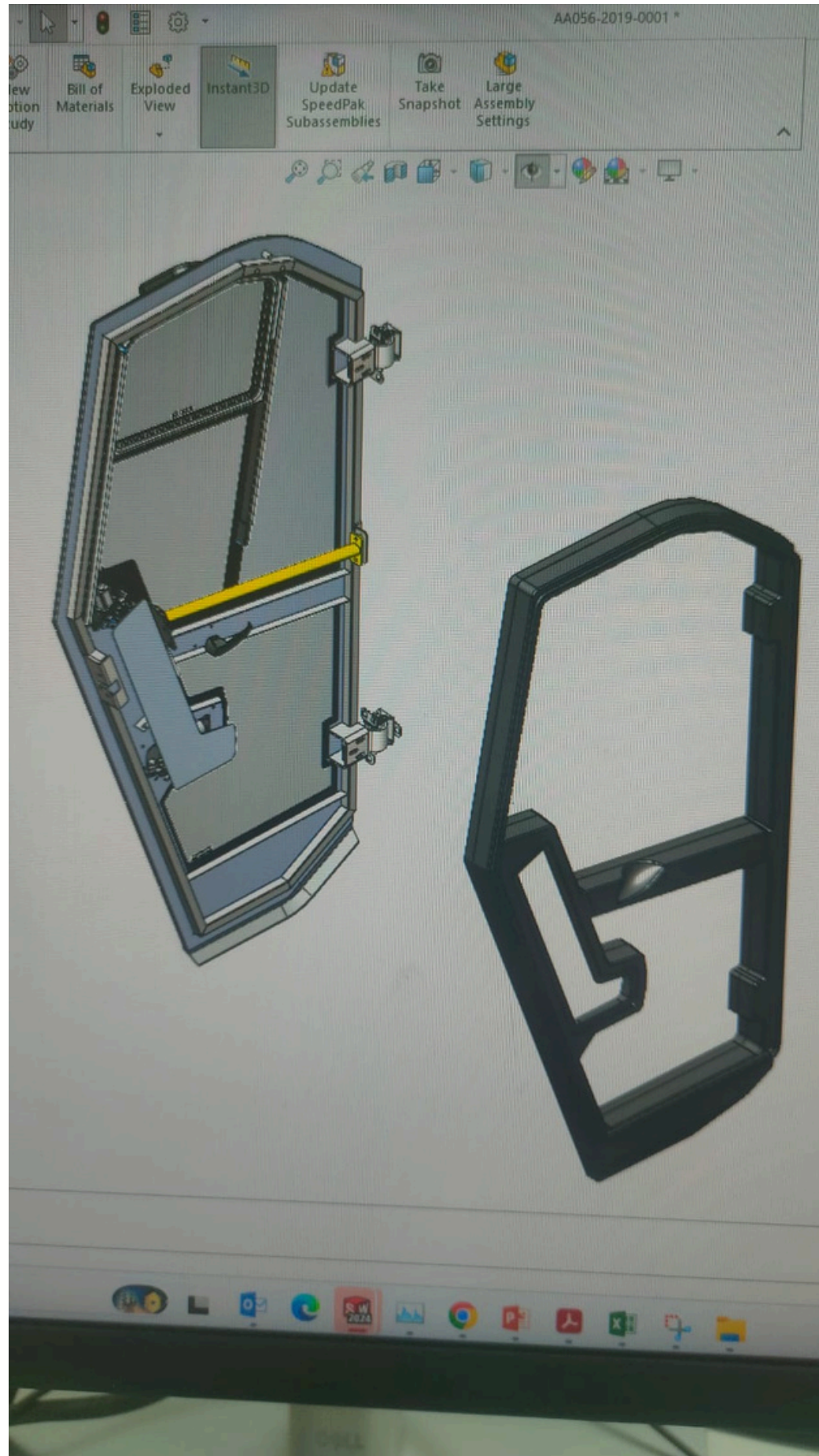

cabin support structure



Trestle assembly

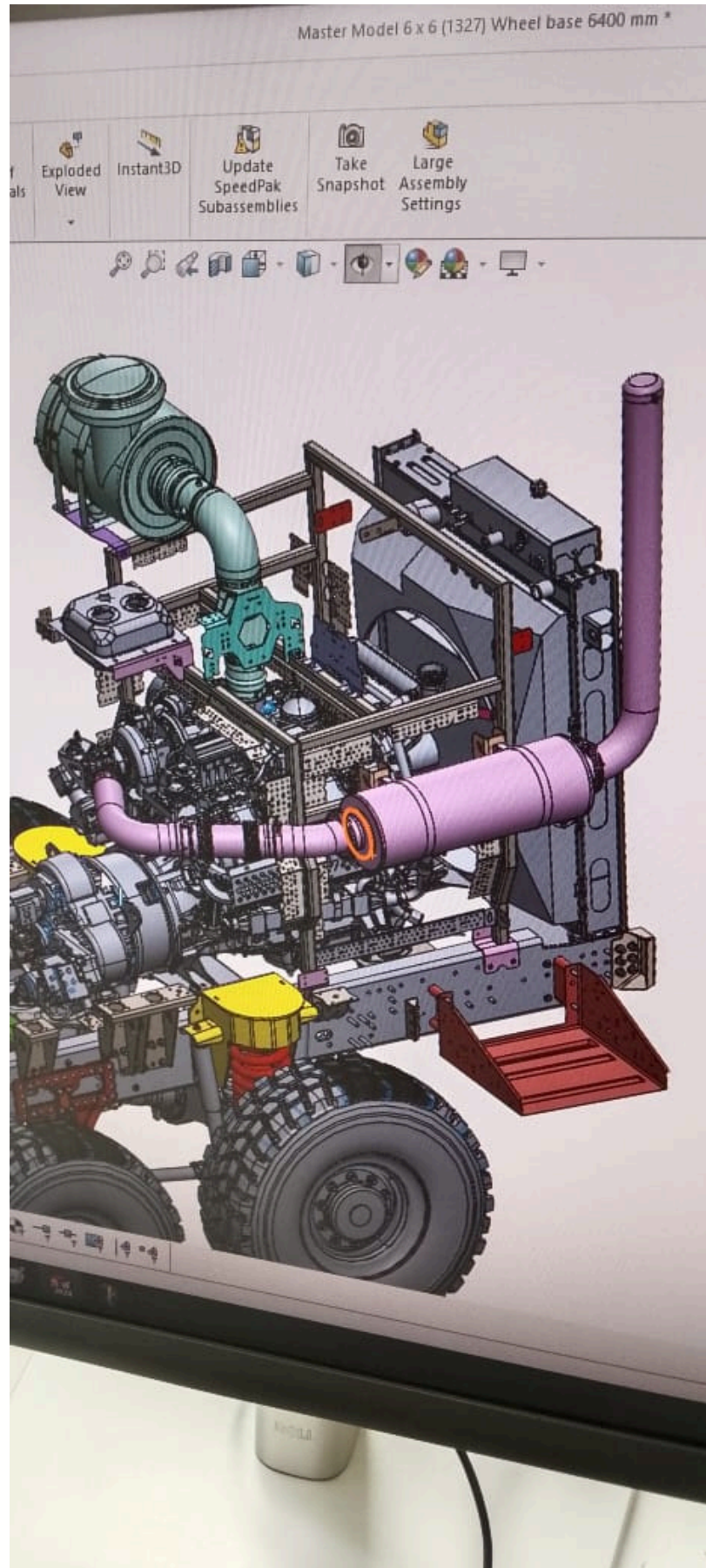

Steering gear mounting bracket

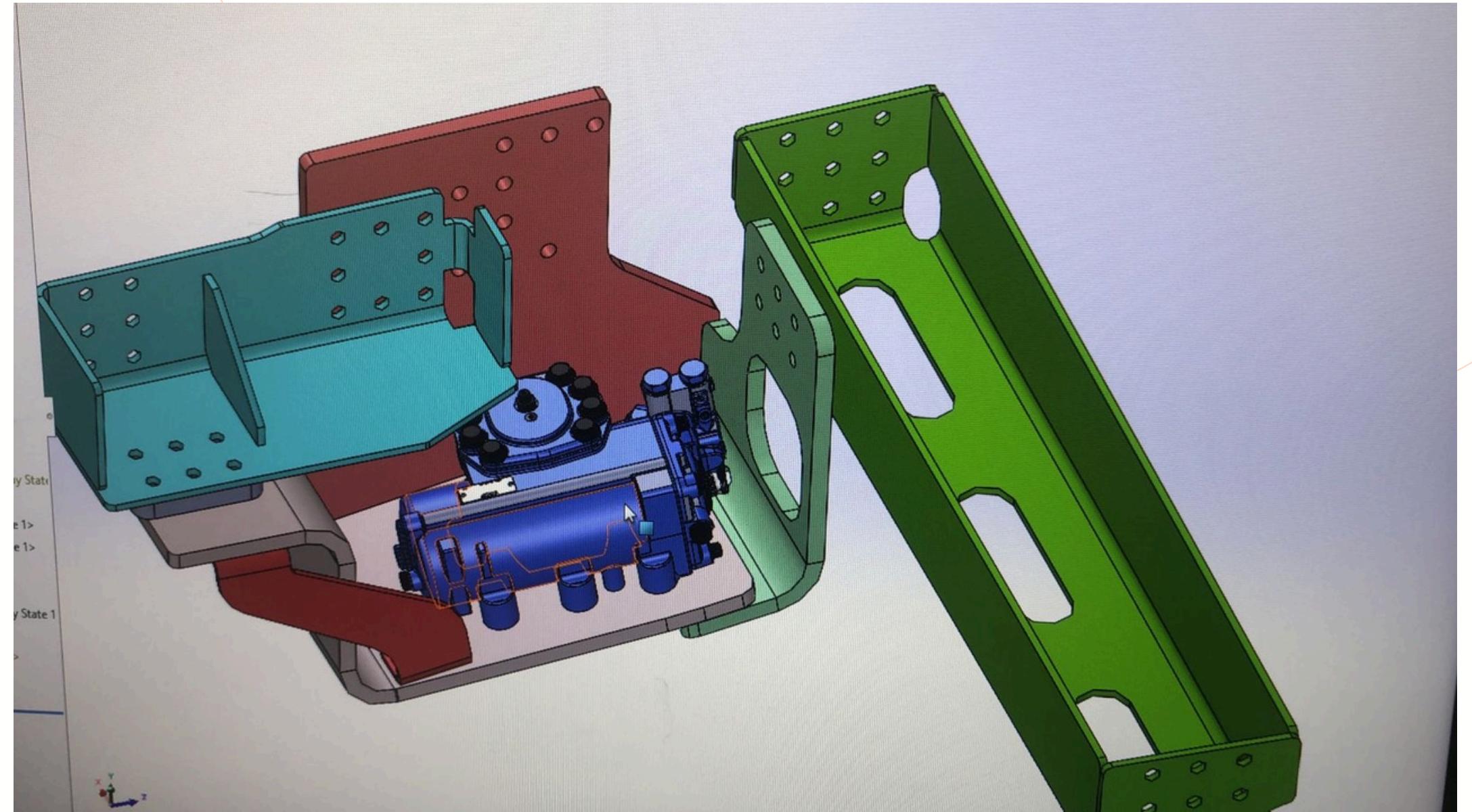

Shock absorber positioning

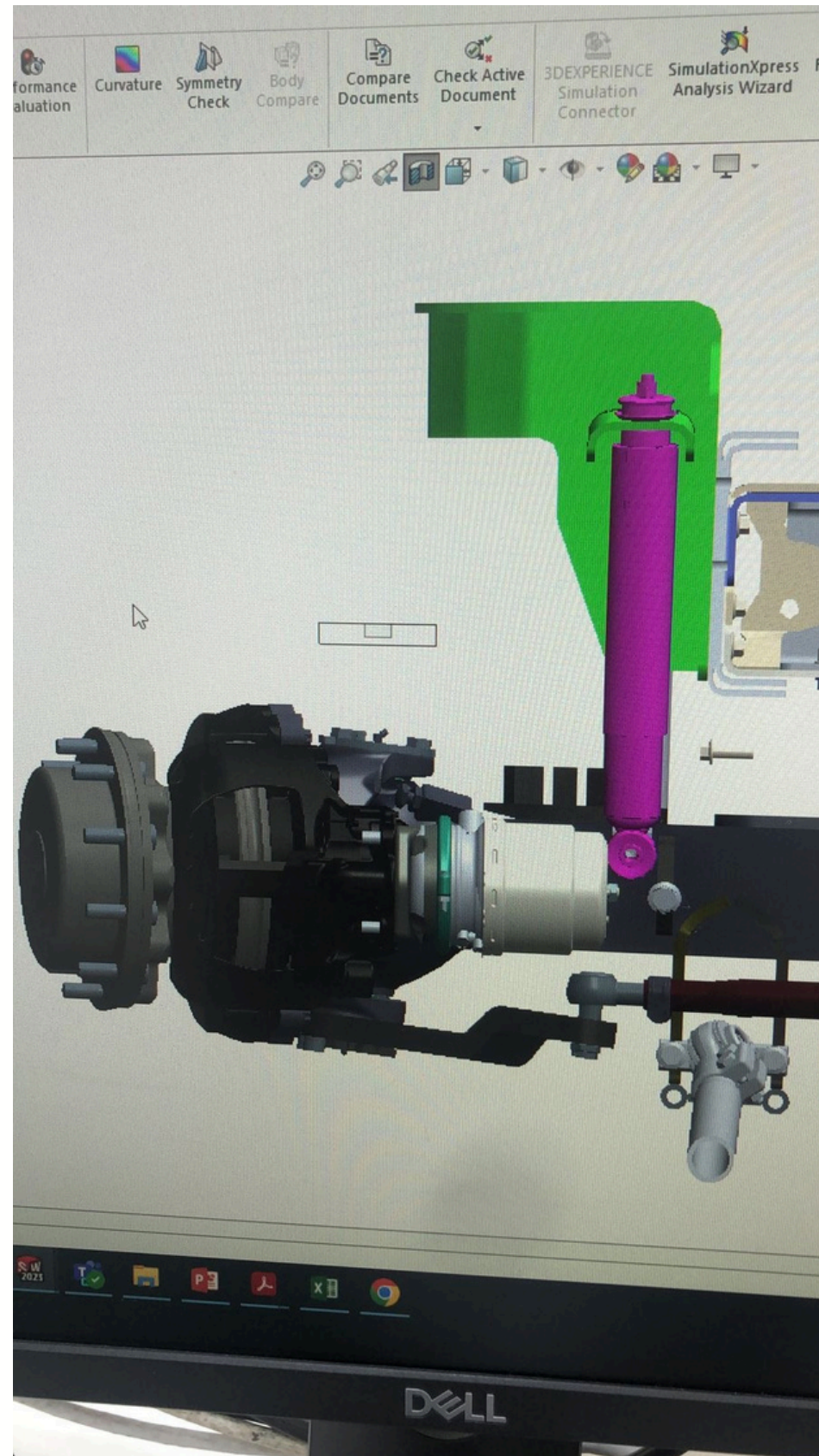

Naffco ARFF



HVAC SYSTEM

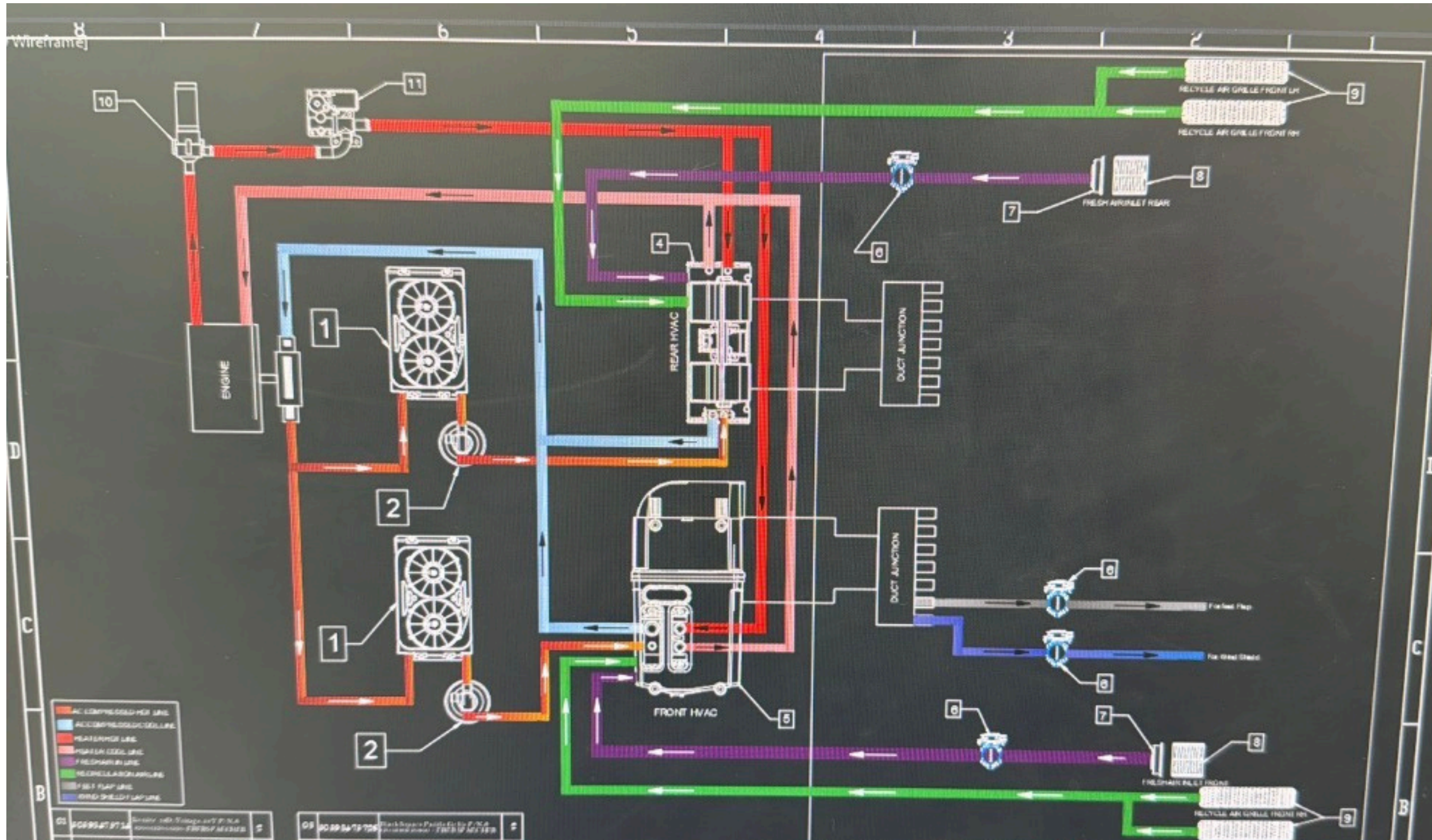

BRAKE SYSTEM

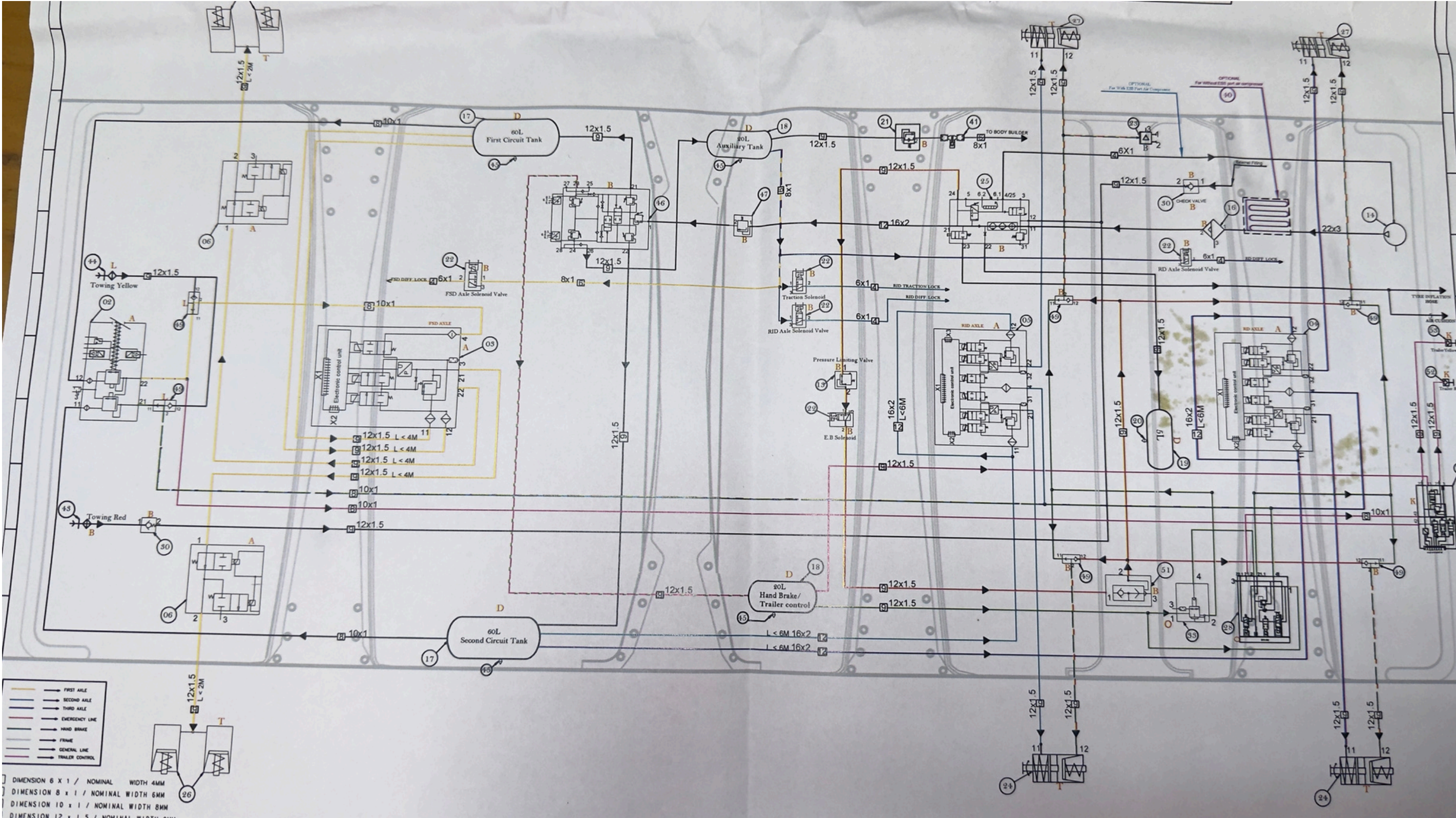

HYDRUALICS AND PNEUMATICS ROUTING

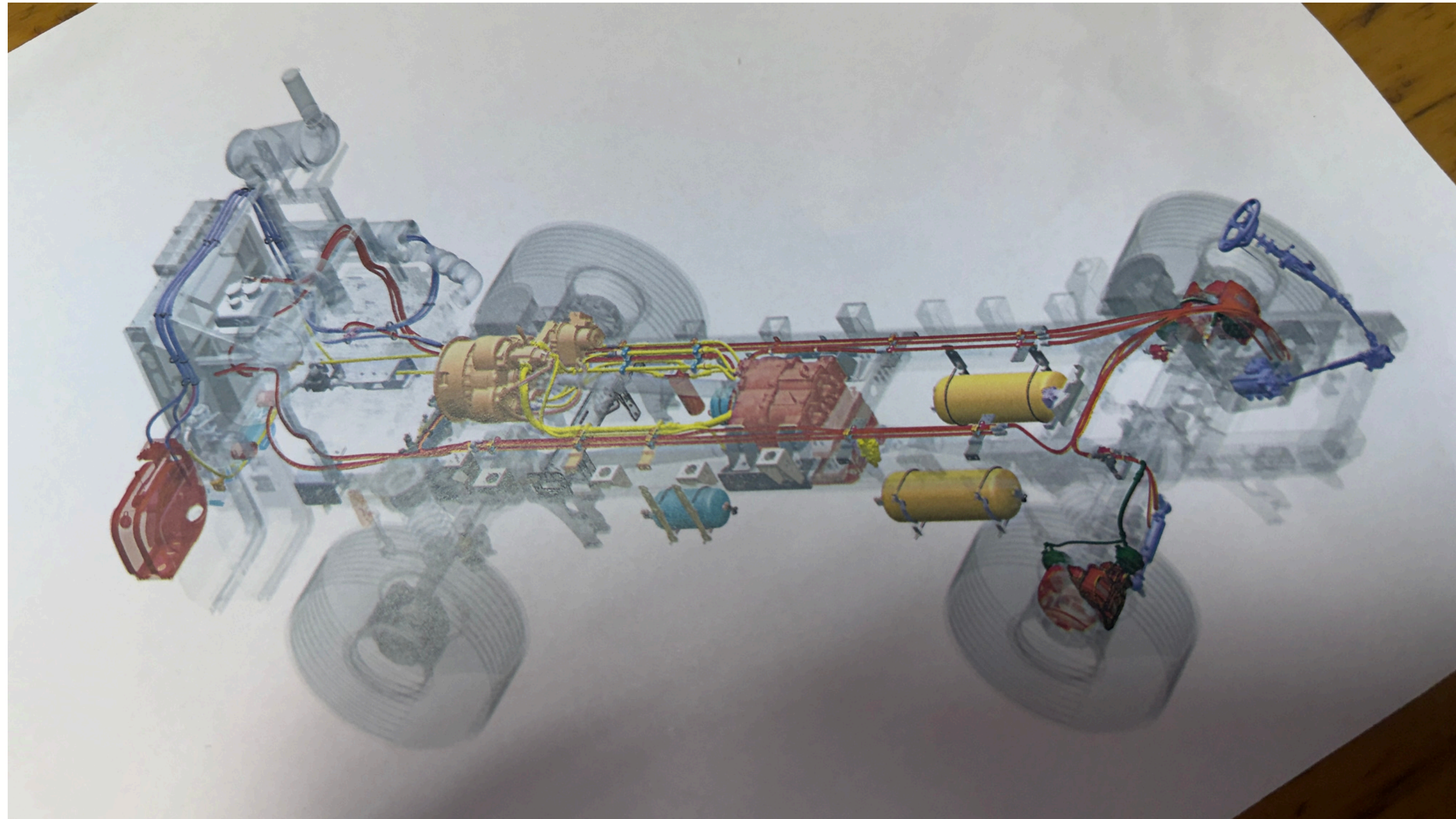

TYRE CURING PRESS-4 tyre

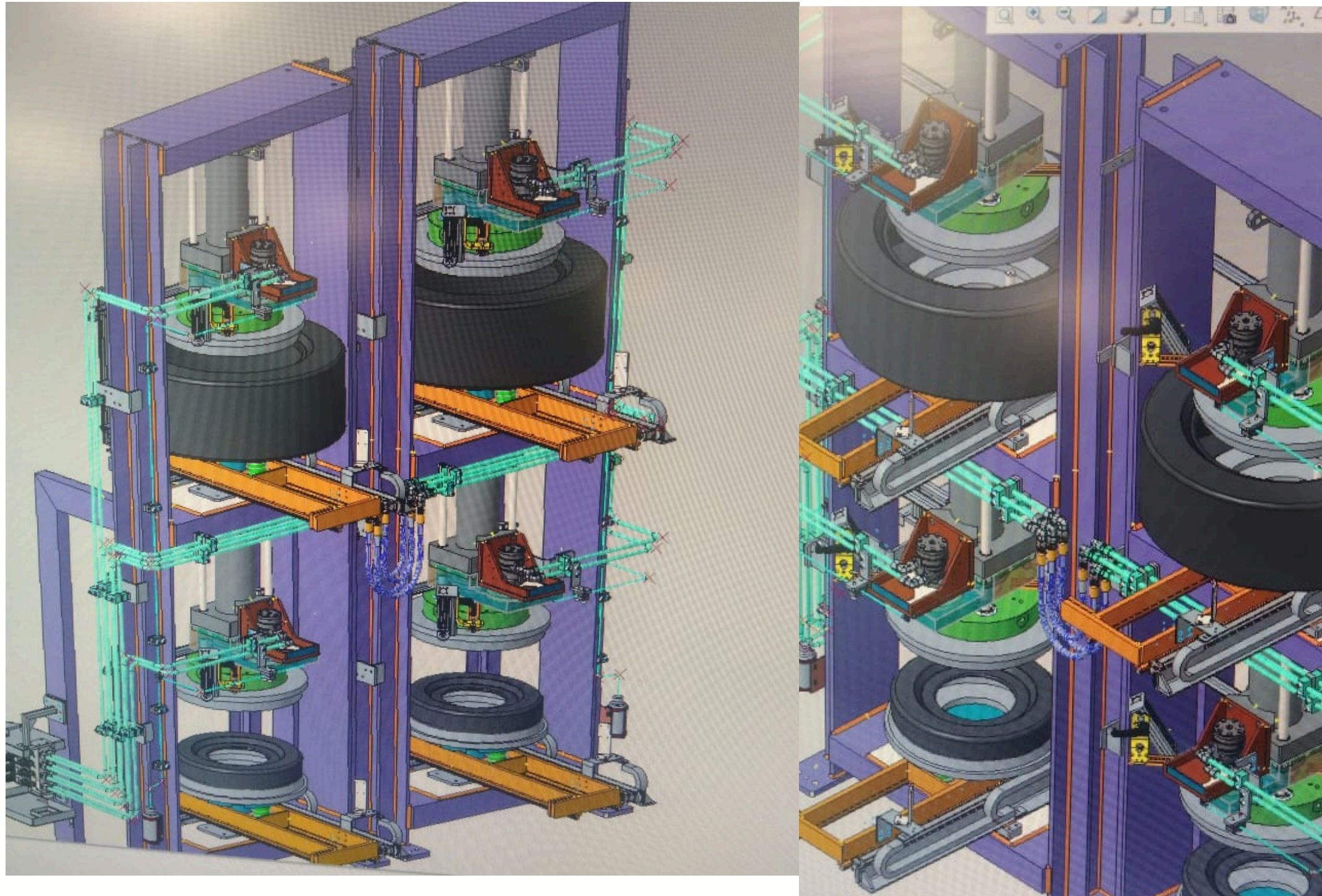

A tyre curing press is a machine used to mold and cure rubber into a tyre shape. It is an essential part of the tyre manufacturing process. The press uses heat and pressure to shape and bond the rubber compound, known as green tyre, to create the final product. The curing process involves applying heat and pressure to the green tyre inside a metal mold, allowing it to take on the desired shape and characteristics. The curing press typically consists of a heavy-duty frame, hydraulic systems for applying pressure, and heating elements to provide the necessary temperature.

hydraulic routing-HTCP

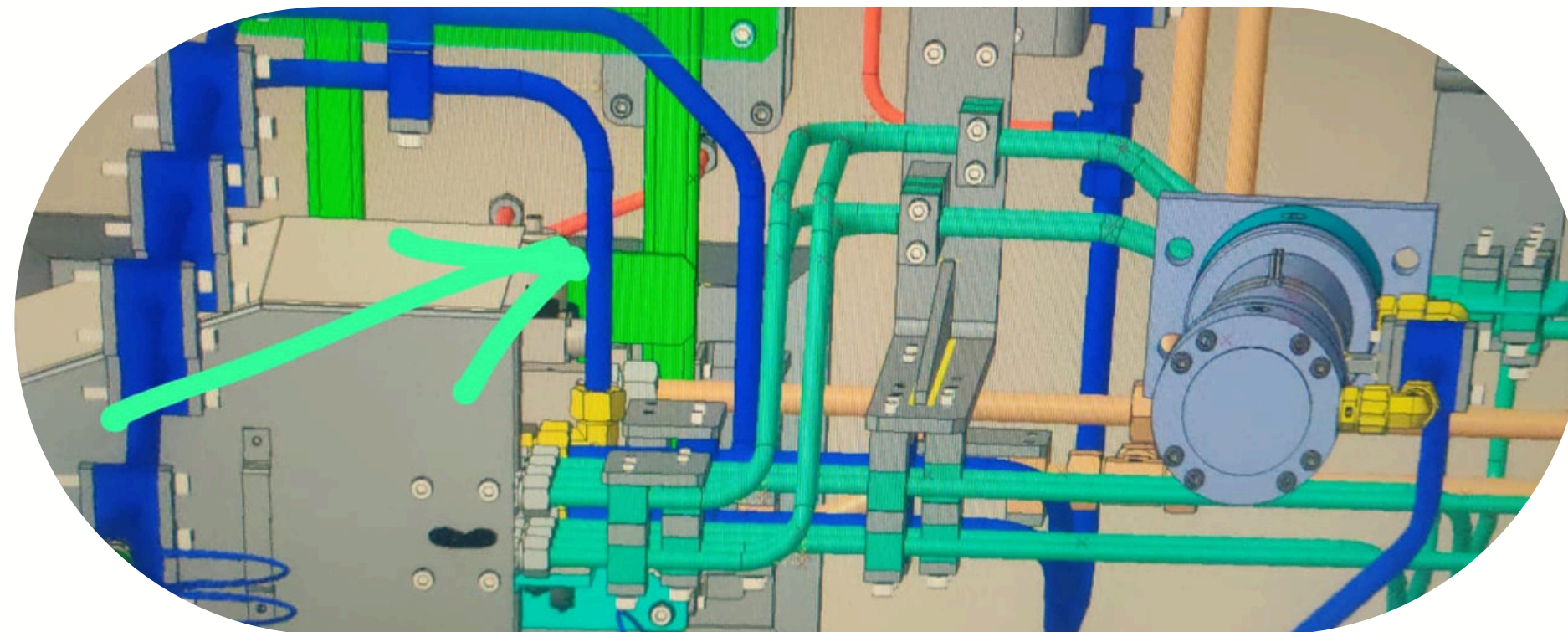
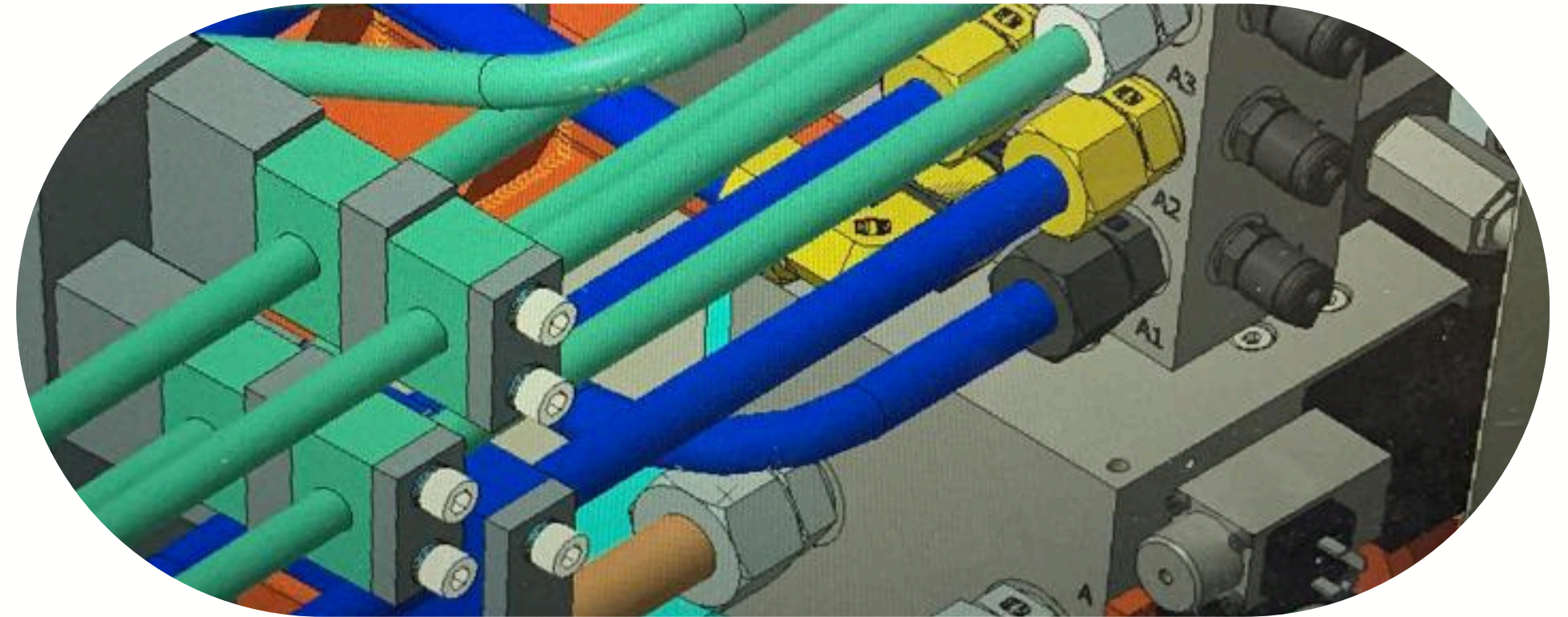

The individual has experience working in hydraulic routing specifically related to tyre curing presses. It is likely that their responsibilities included designing and implementing hydraulic systems within the tyre curing press to ensure proper functionality and efficient operation. A tyre curing press is used in the manufacturing of tires to apply heat and pressure to the raw materials, shaping them into the final tire product. Hydraulic systems play a crucial role in controlling the movement and force applied within the press. Overall, the individual has expertise in hydraulic routing and its application in the context of tyre curing presses.

straddle carrier

As an employee at L&T, you worked on straddle carriers. Straddle carriers are heavy-duty machines used in ports and container terminals for lifting and moving shipping containers. Your role likely involved operating and maintaining these vehicles to ensure efficient and safe container handling. Working with straddle carriers required skills in handling heavy machinery, knowledge of safety protocols, and proficiency in container logistics. Overall, your experience working on straddle carriers at L&T provided you with valuable expertise in container handling operations within the port industry.





CAT-FASTNERS

As a member of the Caterpillar Fasteners design team, I was responsible for converting a 1975-year-old drawing into a CAD model using current technology. I used specialized CAD software and techniques to meticulously recreate the dimensions and details of the original drawing in a digital format.

The process involved carefully analyzing the original drawing's lines, shapes, and specifications. I then used CAD tools to create accurate 2D and 3D representations of the fasteners, considering factors such as material selection, dimensions, tolerances, and manufacturing requirements.

Throughout the conversion process, I collaborated with other team members to ensure the accuracy and compatibility of the CAD model with modern manufacturing processes. We conducted detailed reviews and made necessary modifications to ensure that the model aligned with Caterpillar's current design standards and engineering principles.

The end result was a meticulously crafted CAD model that not only retained the essence of the original 1975 drawing but also met the requirements and specifications demanded by Caterpillar in the present day. This CAD model served as a valuable reference for future design iterations, manufacturing processes, and quality control procedures.



Thank you

Contact Details

Phone : *+971565744784*

Whatsapp : *+917825933423*

Email : *Ranjith.thangapandi2002@gmail.com*